



## شرکت گراد صنعت مایا



WORLD OF ALUMINIUM ACCESSORIES & HARDWARE





## شرکت گراد صنعت مایا

شرکت گراد صنعت مایا با هدف تامین کالا و اکسسوری مورد نیاز شرکت‌ها در حوزه صنعت نما و درب و پنجره و صنایع مختلف تاسیس شده که هدف آن تامین کالای با کیفیت وارداتی در کمترین زمان و مناسبترین قیمت می‌باشد.

شرکت گراد صنعت مایا با توجه به وجود دفتر مرکزی در کشور ترکیه و همچنین انبار محصول در کرج دارای نمایندگی برندهایی از قبیل چسب selsil، رنگ پودری Setas و یراق bossy امکان تامین ملزومات شرکتها را دارا می باشد.



## شرکت Bossy





BOSSY تولیدکننده انواع یراق آلات درب و پنجره آلومینیومی (یراق درب، یراق تک حالت و یراق دو حالت)، بازشو نمای کرتین وال (یراق فریکشن و یراق پارالل) و انواع دستگیره های پنجره های آلومینیومی در طرح ها و رنگ های متنوع می باشد.



# BOSSY CMS-Top Hung Series



NUMBER	PRODUCT NAME	CODE	QUANTITY
01	Friction Stay	801007	2
02	Friction Stay Stage System	851003 851005	2
03	Fixed Striker	821010	2
04	Corner Device	611040	2
05	Adjustable Striker	823010	2
06	Connector	822010	2
07.1	Facade Handle	4012	1
07.2	New Model Jointed Handle	4060 4061	1

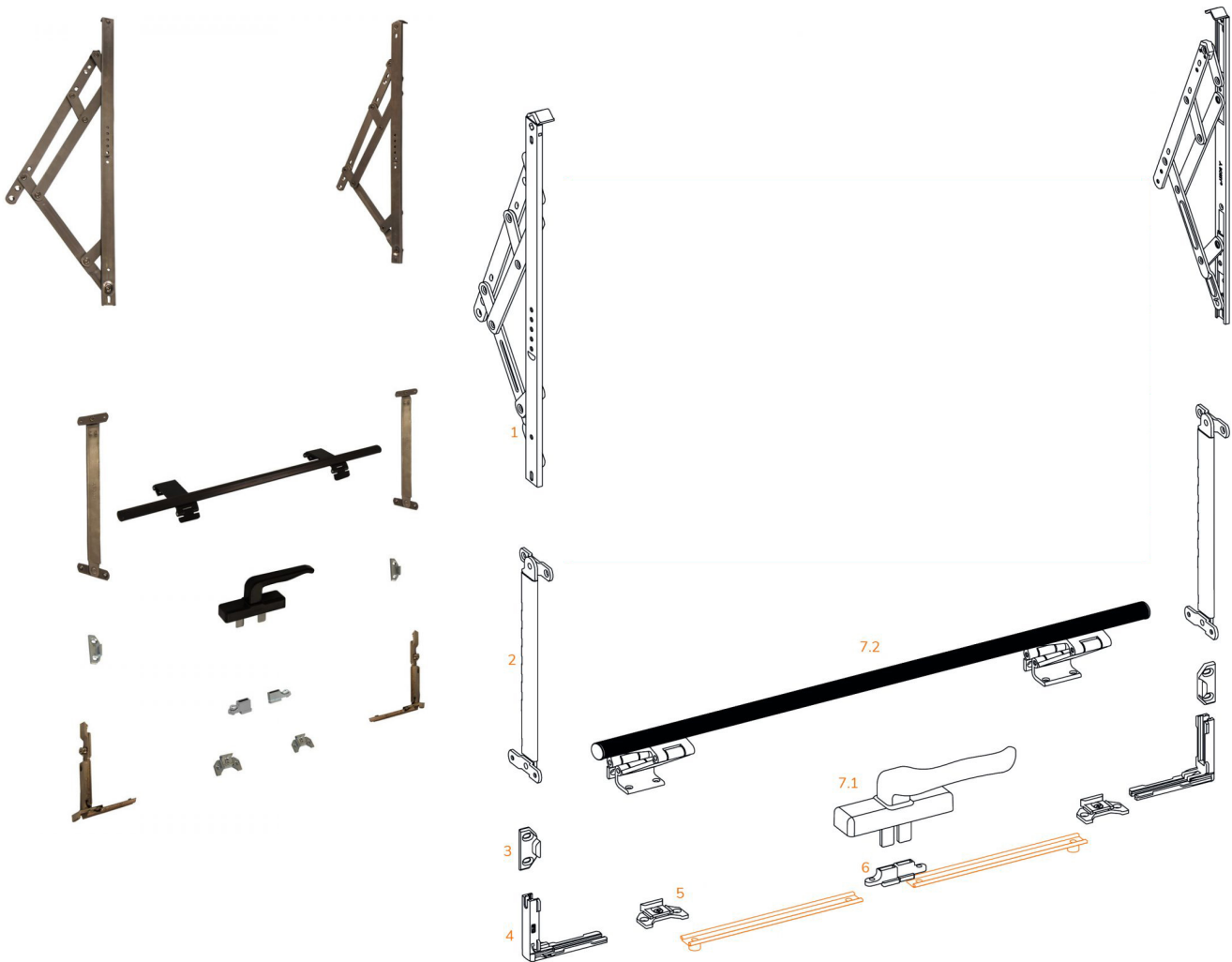

# Friction Stays System

سیستم بازشو فریکشن، مکانیزمی امن برای بازشو در سیستم‌های مدرن نما (کرتین‌وال و ...) می‌باشد که از بسته شدن سیستم توسط نیروهای خارجی جلوگیری کرده و سبک بودن آن باعث شده بهترین گزینه در سیستم‌های نما در نظر گرفته شود.

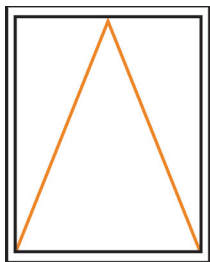

Small Size Friction Stays

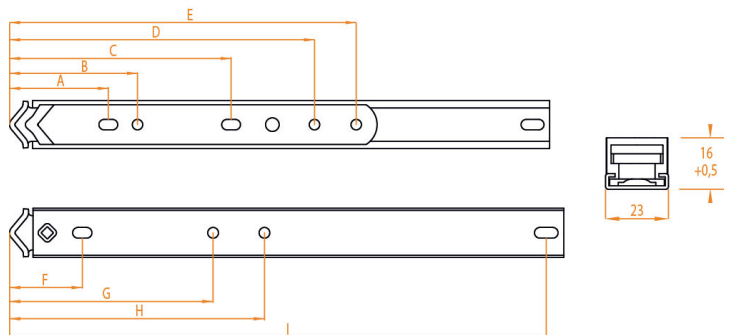

Installation Dimensions (mm)										Technical Parameters				
Size	Item code	A	B	C	D	E	F	G	H	I	Max Opening Angel	Max Height	Max width	Max weight
10	801007	47	61	106	146	167	34	95	119	250	30	700	1200	50
12	801208	44	58	130	170	190	34	189	258	307	30/35	800	1200	60
14	801410	45	59	155	195	216	34	192	295	343	30/35	1000	1300	70
16	801612	44	58	188	227	248	34	309	355	403	25/30	1200	1400	85

# Friction Stays System

## Standart Size Friction Stays

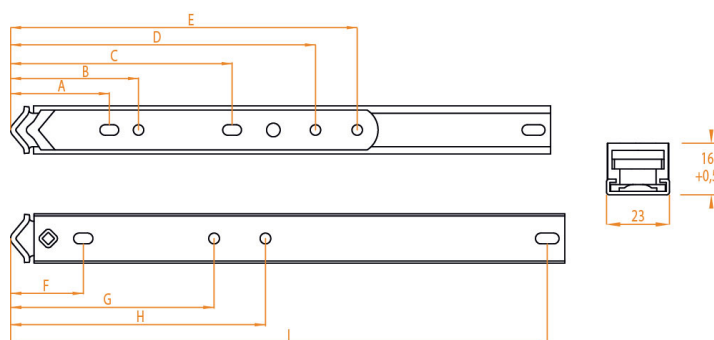
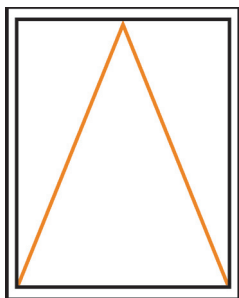

Installation Dimensions (mm)										Technical Parameters				
Size	Item code	A	B	C	D	E	F	G	H	I	Max Opening Angel	Max Height	Max width	Max weight
18	801814	43	57	98	221	261	33	x	399	446	25/30	1400	1400	100
20	802016	44	58	99	249	289	34	318	453	501	20/25	1600	1500	130
22	802217	44	58	99	279	319	34	364	499	547	20/25	1700	1500	135
24	802418	44	58	99	300	340	34	410	545	593	20/25	1800	1500	140
28	802820	44	58	99	363	403	34	515	650	698	20	2000	1500	155



## Heavy Duty Friction Stays

بیراق فریکشن سنگین BOSSY از فولاد ضد زنگ آستنییتی ۳۰۴ با کیفیت بالا برای مدت طولانی ساخته شده است. عمر و مقاومت در برابر خوردگی fhghdd nhvn. این لولا با کیفیت بالا طیف وسیعی از ویژگی های طراحی شده برای افزایش دوام را ارائه می دهد.



### امکانات

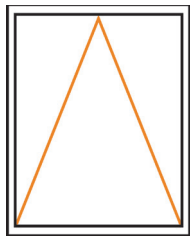

- مناسب برای بازشوهای بزرگتر که در آنها به تحمل وزن بالا نیاز می باشد.
- تنظیم مقدار بازشو با پیچ رگلاژ
- دارای لولای رگلاژ شونده
- کورس ۲۳ میلی متری عریض تر برای تحمل وزن های بیشتر
- ارتفاع پشت تا پشت ۱۶ میلی متر

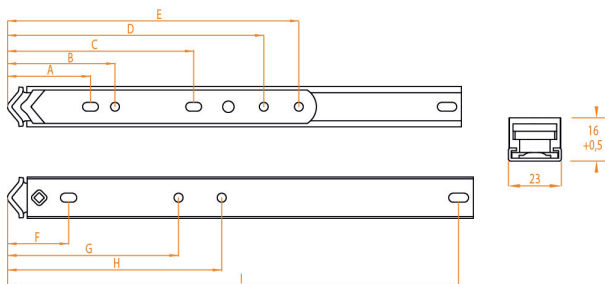

Installation Dimensions (mm)										Technical Parameters				
Size	Item code	A	B	C	D	E	F	G	H	I	Max Opening Angel	Max Height	Max width	Max weight
24	812418	44	58	99	300	340	34	410	545	593	20/25	1800	1500	155
28	8128202	44	58	99	363	403	34	515	650	698	20	2000	1500	185

## Telescopic Arm

بدنه Stage Friction بهینه‌سازی شده تا پنجره‌های بیشتری را شامل شود.

مناسب برای استانداردهای اروپایی

استحکام بالا

بدنه اصلی برای قرار دادن پروفایل‌های بیشتر بهینه شده است.

**3 Telescopic Arm  
851003**

**5 Telescopic Arm  
851005**

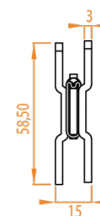
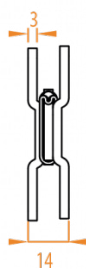
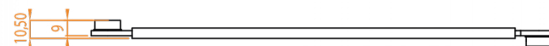
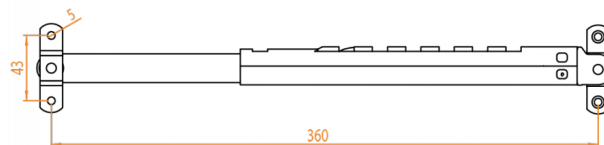
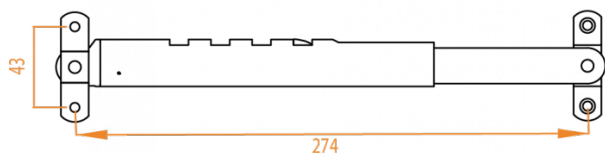
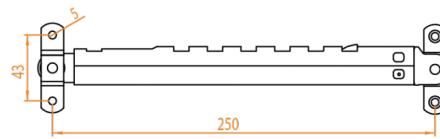
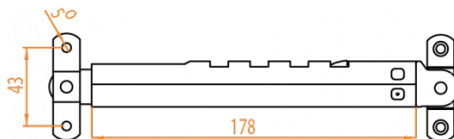

## Restrictive Limitation

محدود کردن زاویه باز شدن از بسته شدن ناگهانی پنجره توسط باد شدید و شکستن پنجره جلوگیری می‌کند.

**Restrictive Limitation Arm (1600 mm)**  
861600



**Restrictive Limitation Arm (2200 mm)**  
862200

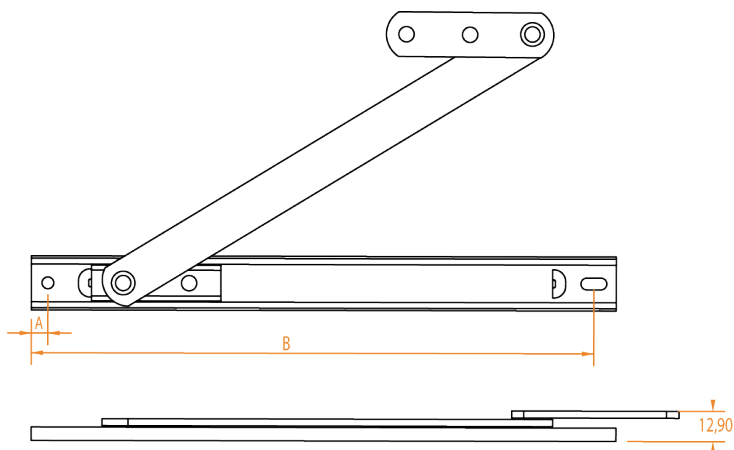

SIZE	ITEM CODE	A	B	MAX HIGHT (mm)
258,94	861600	7	239	1600
258,94	862200	7	239	2200

## Parallel Friction Stay



### لولای بازشو پارالل BOSSY

- بازشوهای پارالل با ایجاد چرخش به جریان هوا در اطراف کل دهانه، تهویه طبیعی نهایی را فراهم می‌کنند
- لولاهای پارالل BOSSY تهویه طبیعی را فراهم می‌کنند و در عین حال خطوط دیدنی زیبایی را برای طراحی نمای مدرن حفظ می‌کنند.

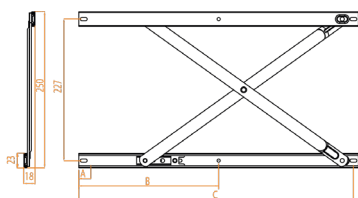
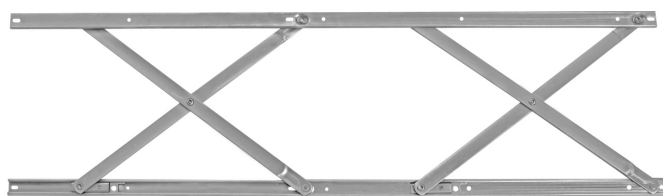
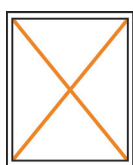

Installation Dimensions (mm)					Technical Parameters			
Size	Item code	A	B	C	Max Opening Angel	Max Height	Max width	Max weight
350	703507	8	217	342	115/205 - 5KD	700	1800	110
450	704509	8	225	442	115/205 - 5KD	900	1800	110

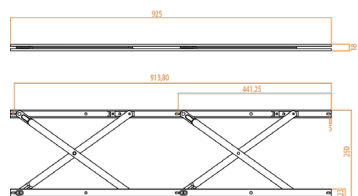

Installation Dimensions (mm)						Technical Parameters				
Size	Item code	A	B	C	D	E	Max Opening Angel	Max Height	Max width	Max weight
670	706714	8	190	339	525	672	115/205 - 5KD	1400	1800	225
920	709218	8	231	444	707	917	115/205 - 5KD	1800	1800	225

## Tilt & Turn Hardware System

این سیستم، پنجره دو حالته و تک حالته که دارای استاندارد Eurou Group می‌باشد.  
تحمل وزنی این سیستم ۱۰۰-۱۳۰ کیلوگرم می‌باشد.  
از این سیستم میتوان برای عرض ۴۸ الی ۱۳۰ سانتی‌متر و ماکسیموم ارتفاع ۲۴۰ سانتی‌متر استفاده نمود.

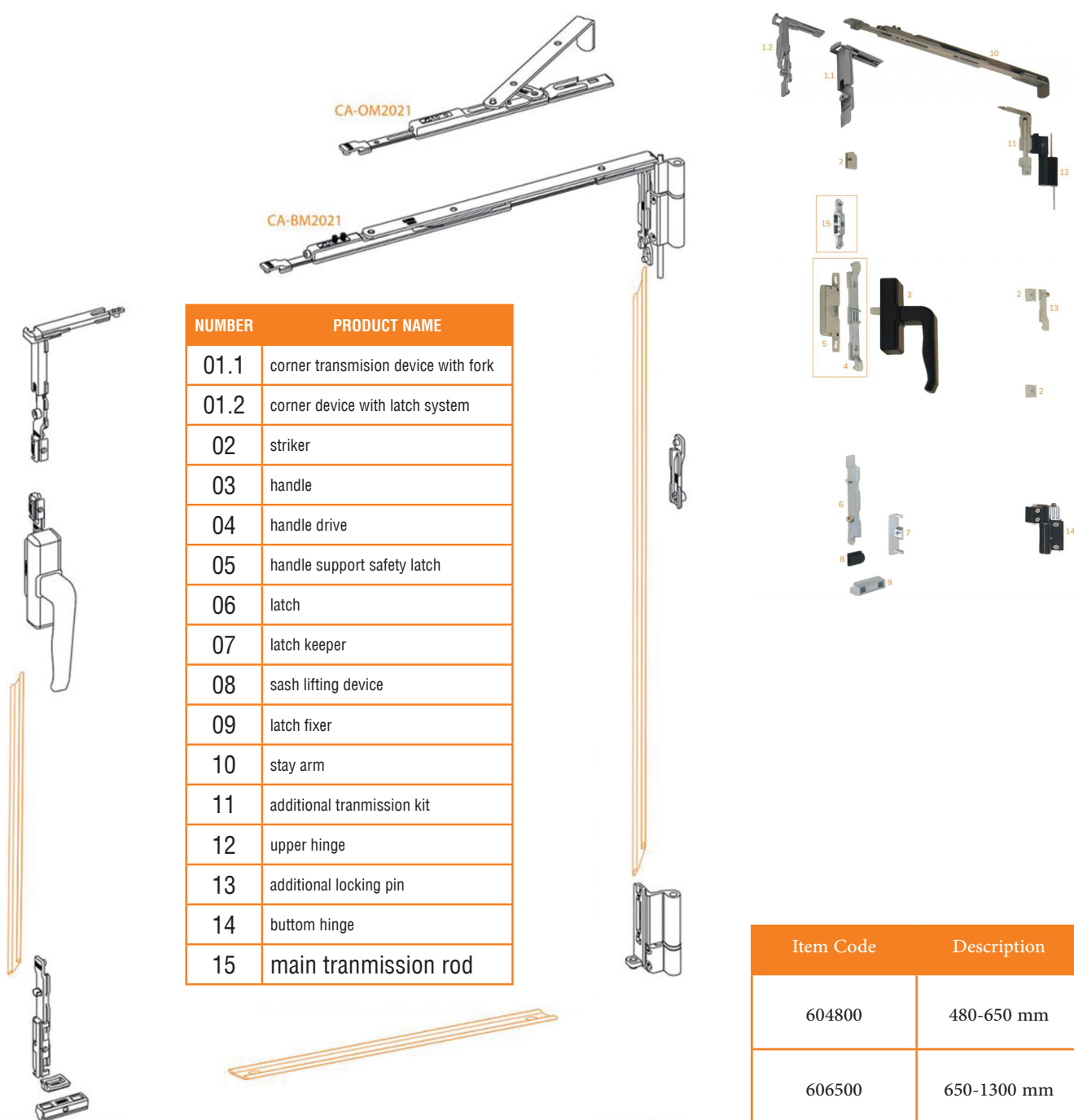

NUMBER	PRODUCT NAME
01.1	corner transmission device with fork
01.2	corner device with latch system
02	striker
03	handle
04	handle drive
05	handle support safety latch
06	latch
07	latch keeper
08	sash lifting device
09	latch fixer
10	stay arm
11	additional tranmission kit
12	upper hinge
13	additional locking pin
14	buttom hinge
15	main tranmission rod

Item Code	Description
604800	480-650 mm
606500	650-1300 mm

**Facade Front Connector  
822010**

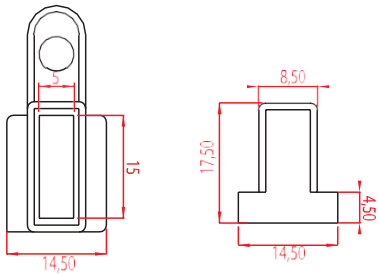

**Adjustable striker  
823010**

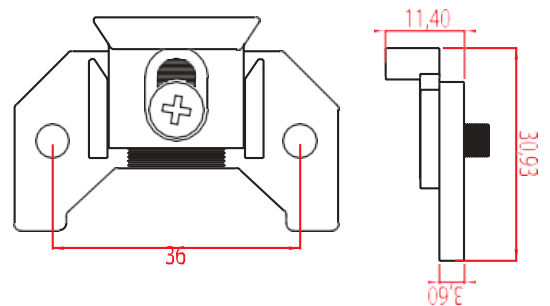
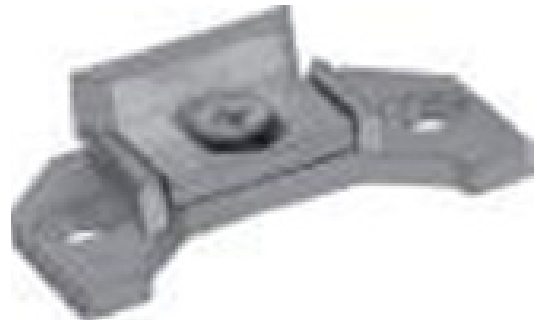

**Fixed Striker A  
824010**

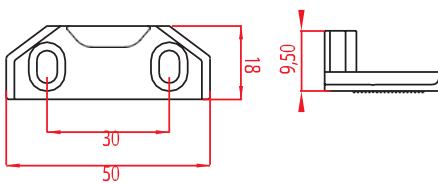

**Fixed Striker B  
821010**

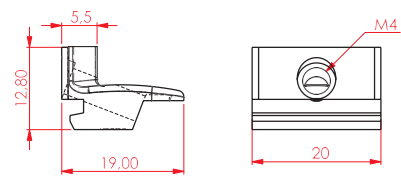

4061

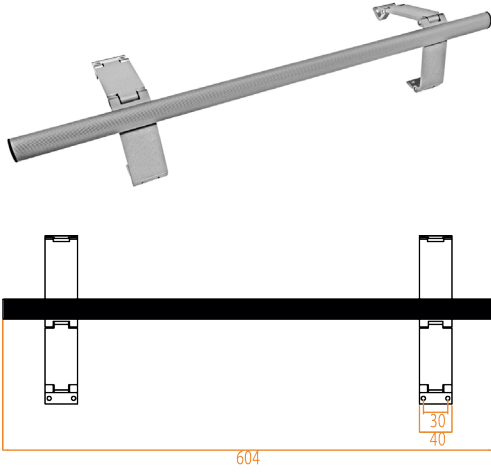

4060

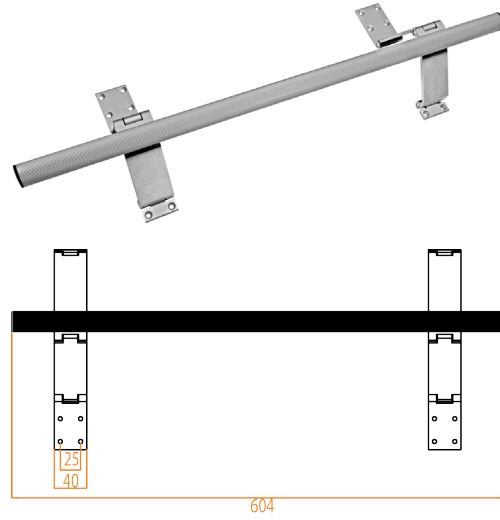

Facade Articulated Arm

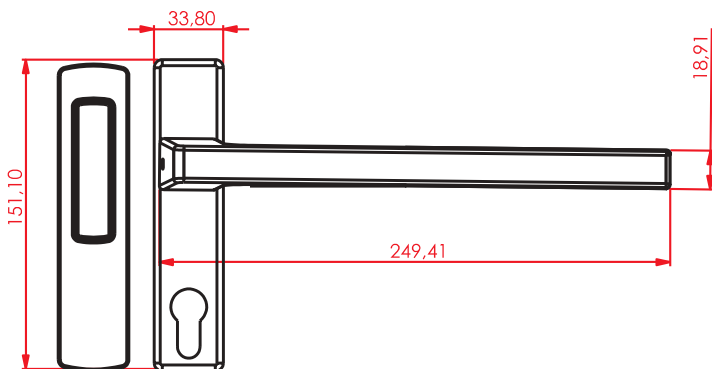

Lift & Slide Handle  
4060

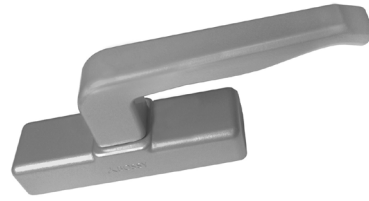
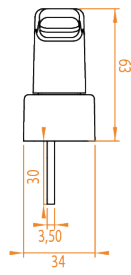
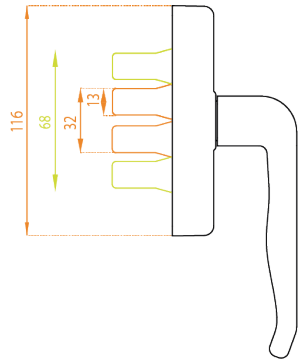
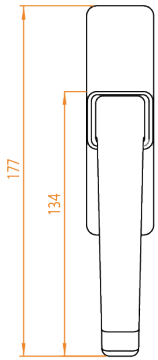

**Flat Model  
Window Cremona**

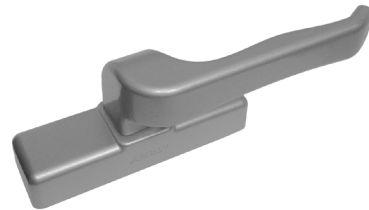
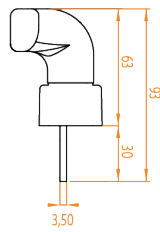
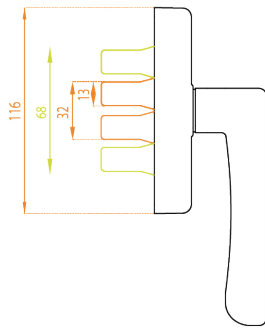
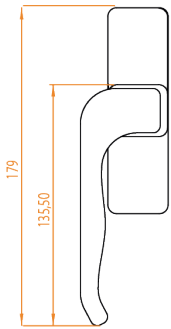

**Curved Model  
Facade Cremona**

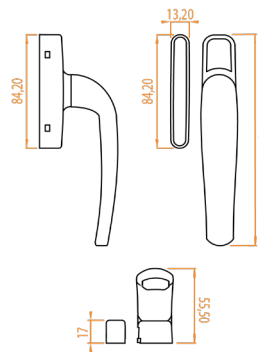

**Cremona with Latch System  
4030**





CK-1003-3 / Double Fork

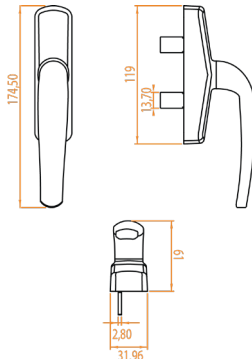

**Axial Oval Handle A**  
4040



4010 / Double Fork

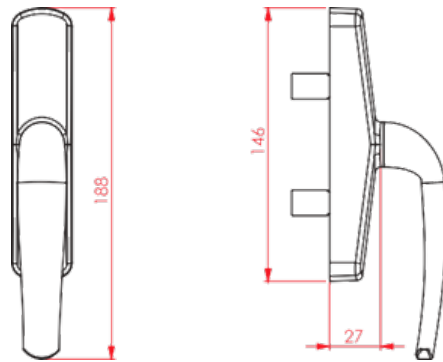

**Axial Oval Handle B**  
4070

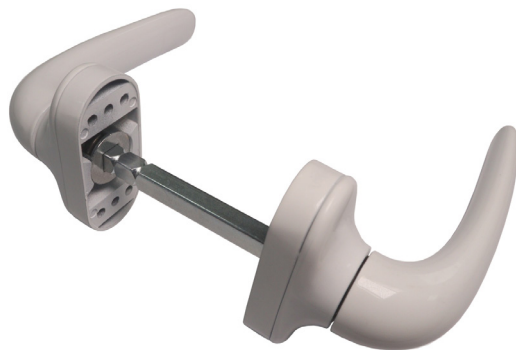
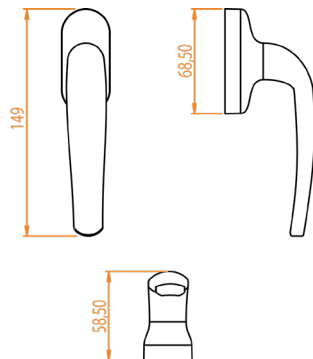

**Lock Lever**  
4050



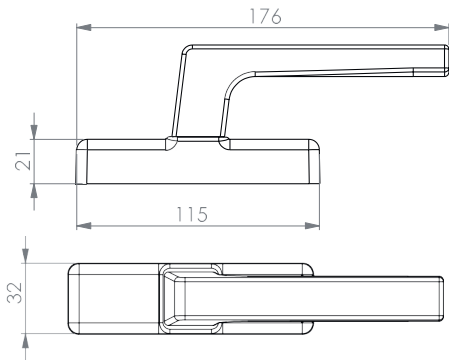

4080 / Short Fork



4081 / NormalFork



4082 / Double Fork



**Novus**  
Windows Cremone

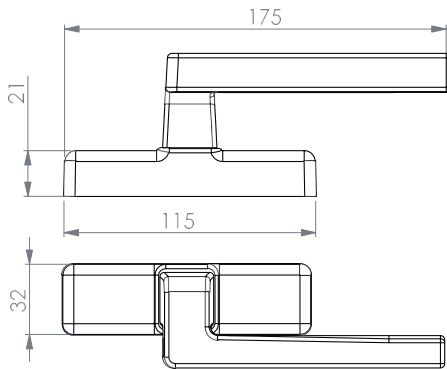

4090 / Short Fork



4091 / NormalFork



4092 / Double Fork



**Novus**  
Facade Cremone

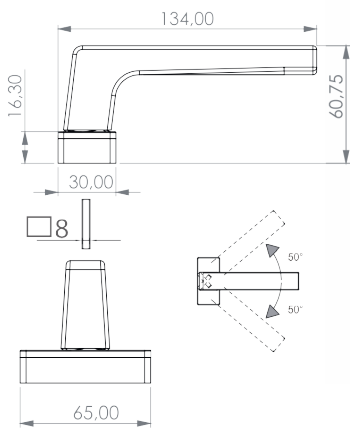

**Novus**  
Door Handles



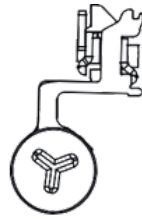
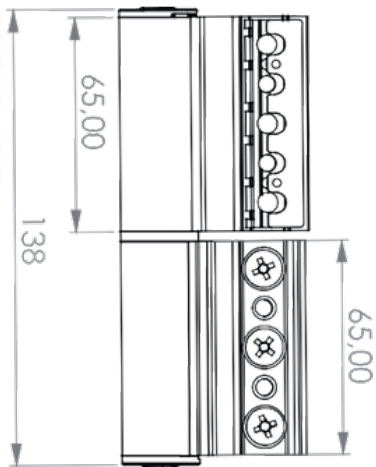

+4mm  
± 2 mm ± 0.5 mm

- 120 kg with 2 Hinges
- 150 kg with 3 Hinges



Fortis Hinges

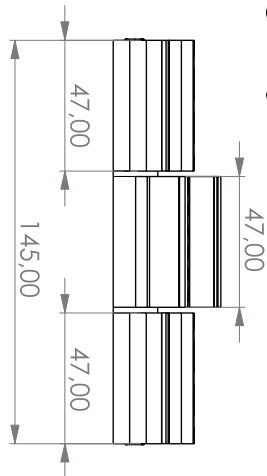

- 100 kg with 2 Hinges



Fortis  
3-Wing Hinges

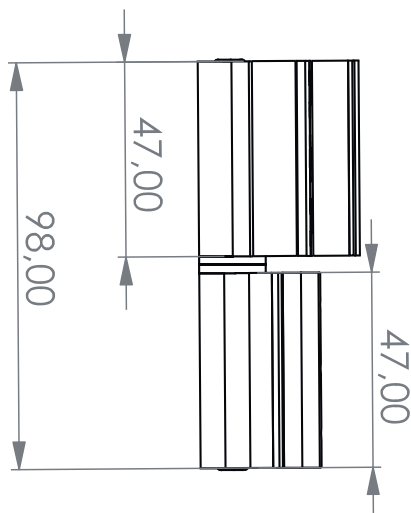

- 80 kg with 2 Hinges



Fortis  
2-Wing Hinges



[www.Grad-Maya.com](http://www.Grad-Maya.com) 

◦9◦587◦867◦ 

◦9◦587◦967◦ 

@Gradsanatmaya 

@gradsanatmaya 

WORLD OF ALUMINIUM ACCESSORIES & HARDWARE